

ESP32-WROOM-32D & ESP32-WROOM-32U

Datasheet



Version 1.7
Espressif Systems
Copyright © 2018

About This Document

This document provides the specifications for the ESP32-WROOM-32D and ESP32-WROOM-32U modules.

Revision History

For revision history of this document, please refer to the [last page](#).

Documentation Change Notification

Espressif provides email notifications to keep customers updated on changes to technical documentation. Please subscribe at www.espressif.com/en/subscribe.

Certification

Download certificates for Espressif products from www.espressif.com/en/certificates.

Disclaimer and Copyright Notice

Information in this document, including URL references, is subject to change without notice. THIS DOCUMENT IS PROVIDED AS IS WITH NO WARRANTIES WHATSOEVER, INCLUDING ANY WARRANTY OF MERCHANTABILITY, NON-INFRINGEMENT, FITNESS FOR ANY PARTICULAR PURPOSE, OR ANY WARRANTY OTHERWISE ARISING OUT OF ANY PROPOSAL, SPECIFICATION OR SAMPLE.

All liability, including liability for infringement of any proprietary rights, relating to use of information in this document is disclaimed. No licenses express or implied, by estoppel or otherwise, to any intellectual property rights are granted herein. The Wi-Fi Alliance Member logo is a trademark of the Wi-Fi Alliance. The Bluetooth logo is a registered trademark of Bluetooth SIG.

All trade names, trademarks and registered trademarks mentioned in this document are property of their respective owners, and are hereby acknowledged.

Copyright © 2018 Espressif Inc. All rights reserved.

Contents

1 Overview	1
2 Pin Definitions	3
2.1 Pin Layout	3
2.2 Pin Description	3
2.3 Strapping Pins	5
3 Functional Description	6
3.1 CPU and Internal Memory	6
3.2 External Flash and SRAM	6
3.3 Crystal Oscillators	6
3.4 RTC and Low-Power Management	7
4 Peripherals and Sensors	8
5 Electrical Characteristics	9
5.1 Absolute Maximum Ratings	9
5.2 Recommended Operating Conditions	9
5.3 DC Characteristics (3.3 V, 25 °C)	9
5.4 Wi-Fi Radio	10
5.5 BLE Radio	10
5.5.1 Receiver	10
5.5.2 Transmitter	11
5.6 Reflow Profile	12
6 Schematics	13
7 Peripheral Schematics	15
8 Physical Dimensions	17
9 Recommended PCB Land Pattern	19
10 U.FL Connector Dimensions	20
11 Learning Resources	21
11.1 Must-Read Documents	21
11.2 Must-Have Resources	21
Revision History	22

List of Tables

1	ESP32-WROOM-32D vs. ESP32-WROOM-32U	1
2	ESP32-WROOM-32D and ESP32-WROOM-32U Specifications	2
3	Pin Definitions	3
4	Strapping Pins	5
5	Absolute Maximum Ratings	9
6	Recommended Operating Conditions	9
7	DC Characteristics (3.3 V, 25 °C)	9
8	Wi-Fi Radio Characteristics	10
9	Receiver Characteristics – BLE	11
10	Transmitter Characteristics – BLE	11

List of Figures

1	ESP32-WROOM-32D Pin Layout (Top View)	3
2	Reflow Profile	12
3	ESP32-WROOM-32D Schematics	13
4	ESP32-WROOM-32U Schematics	14
5	ESP32-WROOM-32D & ESP32-WROOM-32U Peripheral Schematics	15
6	Physical Dimensions of ESP32-WROOM-32D	17
7	Physical Dimensions of ESP32-WROOM-32U	18
8	Recommended PCB Land Pattern of ESP32-WROOM-32D	19
9	Recommended PCB Land Pattern of ESP32-WROOM-32U	19
10	ESP32-WROOM-32U U.FL Dimensions	20

1. Overview

ESP32-WROOM-32D and ESP32-WROOM-32U are powerful, generic Wi-Fi+BT+BLE MCU modules that target a wide variety of applications, ranging from low-power sensor networks to the most demanding tasks, such as voice encoding, music streaming and MP3 decoding.

ESP32-WROOM-32U is different from ESP32-WROOM-32D in that ESP32-WROOM-32U integrates a U.FL connector. For detailed information of the U.FL connector please see Chapter 10. Note that the information in this data sheet is applicable to both modules. Any differences between them will be clearly specified in the course of this document. Table 1 lists the difference between ESP32-WROOM-32D and ESP32-WROOM-32U.

Table 1: ESP32-WROOM-32D vs. ESP32-WROOM-32U

Module	ESP32-WROOM-32D	ESP32-WROOM-32U
Core	ESP32-D0WD	ESP32-D0WD
SPI flash	32 Mbits, 3.3 V	32 Mbits, 3.3 V
Crystal	40 MHz	40 MHz
Antenna	onboard antenna	U.FL connector (which needs to be connected to an external IPEX antenna)
Dimensions (Unit: mm)	(18.00±0.10) x (25.50±0.10) x (3.10±0.10) (See Figure 6 for details)	(18.00±0.10) x (19.20±0.10) x (3.20±0.10) (See Figure 7 for details)
Schematics	See Figure 3 for details.	See Figure 4 for details.

At the core of the two modules is the ESP32-D0WD chip that belongs to the ESP32 series* of chips. The chip embedded is designed to be scalable and adaptive. There are two CPU cores that can be individually controlled, and the CPU clock frequency is adjustable from 80 MHz to 240 MHz. The user may also power off the CPU and make use of the low-power co-processor to constantly monitor the peripherals for changes or crossing of thresholds. ESP32 integrates a rich set of peripherals, ranging from capacitive touch sensors, Hall sensors, SD card interface, Ethernet, high-speed SPI, UART, I²S and I²C.

Note:

* For details on the part numbers of the ESP32 family of chips, please refer to the document [ESP32 Datasheet](#).

The integration of Bluetooth, Bluetooth LE and Wi-Fi ensures that a wide range of applications can be targeted, and that the module is all-around: using Wi-Fi allows a large physical range and direct connection to the Internet through a Wi-Fi router, while using Bluetooth allows the user to conveniently connect to the phone or broadcast low energy beacons for its detection. The sleep current of the ESP32 chip is less than 5 μ A, making it suitable for battery powered and wearable electronics applications. The module supports a data rate of up to 150 Mbps, and 20 dBm output power at the antenna to ensure the widest physical range. As such the module does offer industry-leading specifications and the best performance for electronic integration, range, power consumption, and connectivity.

The operating system chosen for ESP32 is freeRTOS with LwIP; TLS 1.2 with hardware acceleration is built in as well. Secure (encrypted) over the air (OTA) upgrade is also supported, so that users can upgrade their products even after their release, at minimum cost and effort.

Table 2 provides the specifications of ESP32-WROOM-32D and ESP32-WROOM-32U.

Table 2: ESP32-WROOM-32D and ESP32-WROOM-32U Specifications

Categories	Items	Specifications
Certification	RF Certification	FCC/CE-RED/IC/TELEC/KCC/SRRC/NCC
	Wi-Fi Certification	Wi-Fi Alliance
	Bluetooth certification	BQB
	Green Certification	REACH/RoHS
Test	Reliability	HTOL/HTSL/uHAST/TCT/ESD
Wi-Fi	Protocols	802.11 b/g/n (802.11n up to 150 Mbps) A-MPDU and A-MSDU aggregation and 0.4 μ s guard interval support
	Frequency range	2.4 GHz ~ 2.5 GHz
Bluetooth	Protocols	Bluetooth v4.2 BR/EDR and BLE specification
	Radio	NZIF receiver with -97 dBm sensitivity
		Class-1, class-2 and class-3 transmitter
		AFH
Audio	CVSD and SBC	
Hardware	Module interfaces	SD card, UART, SPI, SDIO, I ² C, LED PWM, Motor PWM, I ² S, IR, pulse counter, GPIO, capacitive touch sensor, ADC, DAC
	On-chip sensor	Hall sensor
	Integrated crystal	40 MHz crystal
	Integrated SPI flash ¹	4 MB
	Operating voltage/Power supply	2.7 V ~ 3.6 V
	Operating current	Average: 80 mA
	Minimum current delivered by power supply	500 mA
	Recommended operating temperature range ²	-40 °C ~ +85 °C

Notice:

1. ESP32-WROOM-32D and ESP32-WROOM-32U with 8 MB flash or 16 MB flash are available for custom order.
2. ESP32-WROOM-32D and ESP32-WROOM-32U with high temperature range (-40 °C ~ +105 °C) option are available for custom order. 4 MB SPI flash is supported on the high temperature range version.
3. For detailed ordering information, please see [Espressif Product Ordering Information](#).

2. Pin Definitions

2.1 Pin Layout

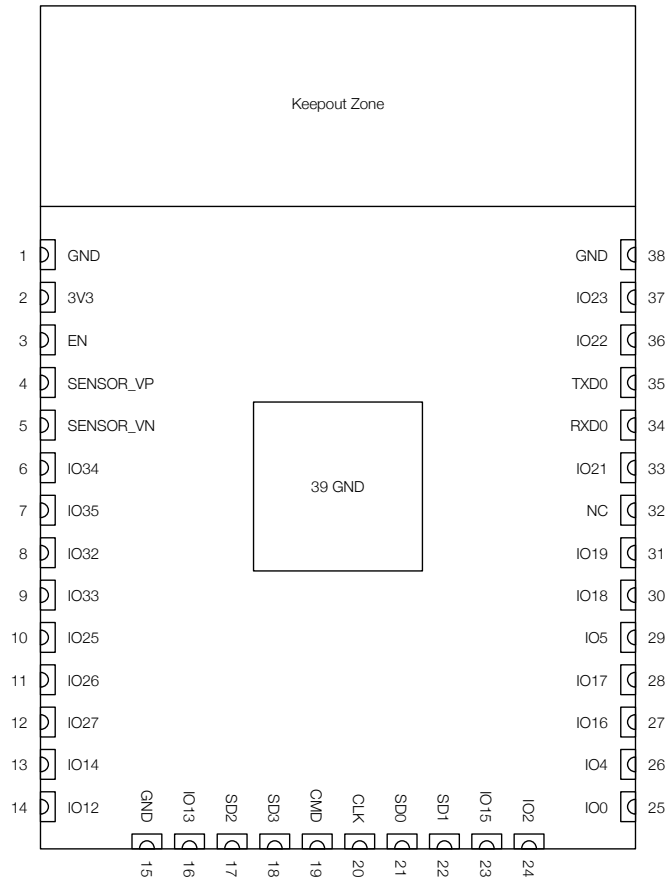

Figure 1: ESP32-WROOM-32D Pin Layout (Top View)

Note:

The pin layout of ESP32-WROOM-32U is the same as that of ESP32-WROOM-32D, except that ESP32-WROOM-32U has no keepout zone.

2.2 Pin Description

The ESP32-WROOM-32D and ESP32-WROOM-32U have 38 pins. See pin definitions in Table 3.

Table 3: Pin Definitions

Name	No.	Type	Function
GND	1	P	Ground
3V3	2	P	Power supply
EN	3	I	Module-enable signal. Active high.
SENSOR_VP	4	I	GPIO36, ADC1_CH0, RTC_GPIO0
SENSOR_VN	5	I	GPIO39, ADC1_CH3, RTC_GPIO3
IO34	6	I	GPIO34, ADC1_CH6, RTC_GPIO4
IO35	7	I	GPIO35, ADC1_CH7, RTC_GPIO5

Name	No.	Type	Function
IO32	8	I/O	GPIO32, XTAL_32K_P (32.768 kHz crystal oscillator input), ADC1_CH4, TOUCH9, RTC_GPIO9
IO33	9	I/O	GPIO33, XTAL_32K_N (32.768 kHz crystal oscillator output), ADC1_CH5, TOUCH8, RTC_GPIO8
IO25	10	I/O	GPIO25, DAC_1, ADC2_CH8, RTC_GPIO6, EMAC_RXD0
IO26	11	I/O	GPIO26, DAC_2, ADC2_CH9, RTC_GPIO7, EMAC_RXD1
IO27	12	I/O	GPIO27, ADC2_CH7, TOUCH7, RTC_GPIO17, EMAC_RX_DV
IO14	13	I/O	GPIO14, ADC2_CH6, TOUCH6, RTC_GPIO16, MTMS, HSPICLK, HS2_CLK, SD_CLK, EMAC_TXD2
IO12	14	I/O	GPIO12, ADC2_CH5, TOUCH5, RTC_GPIO15, MTDI, HSPIQ, HS2_DATA2, SD_DATA2, EMAC_TXD3
GND	15	P	Ground
IO13	16	I/O	GPIO13, ADC2_CH4, TOUCH4, RTC_GPIO14, MTCK, HSPID, HS2_DATA3, SD_DATA3, EMAC_RX_ER
SHD/SD2*	17	I/O	GPIO9, SD_DATA2, SPIHD, HS1_DATA2, U1RXD
SWP/SD3*	18	I/O	GPIO10, SD_DATA3, SPIWP, HS1_DATA3, U1TXD
SCS/CMD*	19	I/O	GPIO11, SD_CMD, SPICS0, HS1_CMD, U1RTS
SCK/CLK*	20	I/O	GPIO6, SD_CLK, SPICLK, HS1_CLK, U1CTS
SDO/SD0*	21	I/O	GPIO7, SD_DATA0, SPIQ, HS1_DATA0, U2RTS
SDI/SD1*	22	I/O	GPIO8, SD_DATA1, SPID, HS1_DATA1, U2CTS
IO15	23	I/O	GPIO15, ADC2_CH3, TOUCH3, MTDO, HSPICS0, RTC_GPIO13, HS2_CMD, SD_CMD, EMAC_RXD3
IO2	24	I/O	GPIO2, ADC2_CH2, TOUCH2, RTC_GPIO12, HSPiWP, HS2_DATA0, SD_DATA0
IO0	25	I/O	GPIO0, ADC2_CH1, TOUCH1, RTC_GPIO11, CLK_OUT1, EMAC_TX_CLK
IO4	26	I/O	GPIO4, ADC2_CH0, TOUCH0, RTC_GPIO10, HSPiHD, HS2_DATA1, SD_DATA1, EMAC_TX_ER
IO16	27	I/O	GPIO16, HS1_DATA4, U2RXD, EMAC_CLK_OUT
IO17	28	I/O	GPIO17, HS1_DATA5, U2TXD, EMAC_CLK_OUT_180
IO5	29	I/O	GPIO5, VSPICS0, HS1_DATA6, EMAC_RX_CLK
IO18	30	I/O	GPIO18, VSPICLK, HS1_DATA7
IO19	31	I/O	GPIO19, VSPIQ, U0CTS, EMAC_TXD0
NC	32	-	-
IO21	33	I/O	GPIO21, VSPIHD, EMAC_TX_EN
RXD0	34	I/O	GPIO3, U0RXD, CLK_OUT2
TXD0	35	I/O	GPIO1, U0TXD, CLK_OUT3, EMAC_RXD2
IO22	36	I/O	GPIO22, VSPiWP, U0RTS, EMAC_TXD1
IO23	37	I/O	GPIO23, VSPID, HS1_STROBE
GND	38	P	Ground

Notice:

* Pins SCK/CLK, SDO/SD0, SDI/SD1, SHD/SD2, SWP/SD3 and SCS/CMD, namely, GPIO6 to GPIO11 are connected to the integrated SPI flash integrated on the module and are not recommended for other uses.

2.3 Strapping Pins

ESP32 has five strapping pins, which can be seen in Chapter 6 Schematics:

- MTDI
- GPIO0
- GPIO2
- MTDO
- GPIO5

Software can read the values of these five bits from register "GPIO_STRAPPING".

During the chip's system reset (power-on-reset, RTC watchdog reset and brownout reset), the latches of the strapping pins sample the voltage level as strapping bits of "0" or "1", and hold these bits until the chip is powered down or shut down. The strapping bits configure the device's boot mode, the operating voltage of VDD_SDIO and other initial system settings.

Each strapping pin is connected to its internal pull-up/pull-down during the chip reset. Consequently, if a strapping pin is unconnected or the connected external circuit is high-impedance, the internal weak pull-up/pull-down will determine the default input level of the strapping pins.

To change the strapping bit values, users can apply the external pull-down/pull-up resistances, or use the host MCU's GPIOs to control the voltage level of these pins when powering on ESP32.

After reset, the strapping pins work as normal-function pins.

Refer to Table 4 for a detailed boot-mode configuration by strapping pins.

Table 4: Strapping Pins

Voltage of Internal LDO (VDD_SDIO)					
Pin	Default	3.3 V		1.8 V	
MTDI	Pull-down	0		1	
Bootling Mode					
Pin	Default	SPI Boot		Download Boot	
GPIO0	Pull-up	1		0	
GPIO2	Pull-down	Don't-care		0	
Enabling/Disabling Debugging Log Print over U0TXD During Bootling					
Pin	Default	U0TXD Active		U0TXD Silent	
MTDO	Pull-up	1		0	
Timing of SDIO Slave					
Pin	Default	Falling-edge Input Falling-edge Output	Falling-edge Input Rising-edge Output	Rising-edge Input Falling-edge Output	Rising-edge Input Rising-edge Output
MTDO	Pull-up	0	0	1	1
GPIO5	Pull-up	0	1	0	1

Note:

- Firmware can configure register bits to change the settings of "Voltage of Internal LDO (VDD_SDIO)" and "Timing of SDIO Slave" after bootling.
- Both ESP32-WROOM-32D and ESP32-WROOM-32U integrate a 3.3 V SPI flash, so the pin MTDI cannot be set to 1 when the modules are powered up.

3. Functional Description

This chapter describes the modules and functions integrated in ESP32-WROOM-32D and ESP32-WROOM-32U.

3.1 CPU and Internal Memory

ESP32-D0WD contains a dual-core Xtensa® 32-bit LX6 MCU. The internal memory includes:

- 448 KB of ROM for booting and core functions.
- 520 KB of on-chip SRAM for data and instructions.
- 8 KB of SRAM in RTC, which is called RTC FAST Memory and can be used for data storage; it is accessed by the main CPU during RTC Boot from the Deep-sleep mode.
- 8 KB of SRAM in RTC, which is called RTC SLOW Memory and can be accessed by the co-processor during the Deep-sleep mode.
- 1 Kbit of eFuse: 256 bits are used for the system (MAC address and chip configuration) and the remaining 768 bits are reserved for customer applications, including flash-encryption and chip-ID.

3.2 External Flash and SRAM

ESP32 supports multiple external QSPI flash and SRAM chips. More details can be found in Chapter SPI in the [ESP32 Technical Reference Manual](#). ESP32 also supports hardware encryption/decryption based on AES to protect developers' programs and data in flash.

ESP32 can access the external QSPI flash and SRAM through high-speed caches.

- The external flash can be mapped into CPU instruction memory space and read-only memory space simultaneously.
 - When external flash is mapped into CPU instruction memory space, up to 11 MB + 248 KB can be mapped at a time. Note that if more than 3 MB + 248 KB are mapped, cache performance will be reduced due to speculative reads by the CPU.
 - When external flash is mapped into read-only data memory space, up to 4 MB can be mapped at a time. 8-bit, 16-bit and 32-bit reads are supported.
- External SRAM can be mapped into CPU data memory space. Up to 4 MB can be mapped at a time. 8-bit, 16-bit and 32-bit reads and writes are supported.

Both ESP32-WROOM-32D and ESP32-WROOM-32U integrate a 4 MB of external SPI flash. The integrated SPI flash is connected to GPIO6, GPIO7, GPIO8, GPIO9, GPIO10 and GPIO11. These six pins cannot be used as regular GPIOs.

3.3 Crystal Oscillators

The module uses a 40-MHz crystal oscillator.

3.4 RTC and Low-Power Management

With the use of advanced power-management technologies, ESP32 can switch between different power modes.

For details on ESP32's power consumption in different power modes, please refer to section "RTC and Low-Power Management" in [ESP32 Datasheet](#).

4. Peripherals and Sensors

Please refer to Section Peripherals and Sensors in [ESP32 Datasheet](#).

Note:

External connections can be made to any GPIO except for GPIOs in the range 6-11. These six GPIOs are connected to the module's integrated SPI flash. For details, please see Section 6 Schematics.

5. Electrical Characteristics

5.1 Absolute Maximum Ratings

Stresses beyond the absolute maximum ratings listed in Table 5 below may cause permanent damage to the device. These are stress ratings only, and do not refer to the functional operation of the device that should follow the [recommended operating conditions](#).

Table 5: Absolute Maximum Ratings

Symbol	Parameter	Min	Max	Unit
VDD33	Power supply voltage	-0.3	3.6	V
I_O^1	Cumulative IO output current	-	1,100	mA
T_{store}	Storage temperature	-40	150	°C

1. The module worked properly after a 24-hour test in ambient temperature at 25 °C, and the IOs in three domains (VDD3P3_RTC, VDD3P3_CPU, VDD_SDIO) output high logic level to ground. Please note that pins occupied by flash and/or PSRAM in the VDD_SDIO power domain were excluded from the test.
2. Please see Appendix IO_MUX of [ESP32 Datasheet](#) for IO's power domain.

5.2 Recommended Operating Conditions

Table 6: Recommended Operating Conditions

Symbol	Parameter	Min	Typical	Max	Unit
VDD33	Power supply voltage	2.7	3.3	3.6	V
I_{VDD}	Current delivered by external power supply	0.5	-	-	A
T	Operating temperature	-40	-	85	°C

5.3 DC Characteristics (3.3 V, 25 °C)

Table 7: DC Characteristics (3.3 V, 25 °C)

Symbol	Parameter		Min	Typ	Max	Unit
C_{IN}	Pin capacitance		-	2	-	pF
V_{IH}	High-level input voltage		$0.75 \times V_{DD}^1$	-	$V_{DD}^1 + 0.3$	V
V_{IL}	Low-level input voltage		-0.3	-	$0.25 \times V_{DD}^1$	V
I_{IH}	High-level input current		-	-	50	nA
I_{IL}	Low-level input current		-	-	50	nA
V_{OH}	High-level output voltage		$0.8 \times V_{DD}^1$	-	-	V
V_{OL}	Low-level output voltage		-	-	$0.1 \times V_{DD}^1$	V
I_{OH}	High-level source current ($V_{DD}^1 = 3.3$ V, $V_{OH} \geq 2.64$ V, output drive strength set to the maximum)	VDD3P3_CPU power domain ^{1, 2}	-	40	-	mA
		VDD3P3_RTC power domain ^{1, 2}	-	40	-	mA
		VDD_SDIO power domain ^{1, 3}	-	20	-	mA

Symbol	Parameter	Min	Typ	Max	Unit
I_{OL}	Low-level sink current ($V_{DD}^1 = 3.3\text{ V}$, $V_{OL} = 0.495\text{ V}$, output drive strength set to the maximum)	-	28	-	mA
R_{PU}	Resistance of internal pull-up resistor	-	45	-	k Ω
R_{PD}	Resistance of internal pull-down resistor	-	45	-	k Ω
V_{IL_nRST}	Low-level input voltage of CHIP_PU to reset the chip	-	-	0.6	V

Notes:

1. Please see Appendix IO_MUX of [ESP32 Datasheet](#) for IO's power domain. VDD is the I/O voltage for a particular power domain of pins.
2. For VDD3P3_CPU and VDD3P3_RTC power domain, per-pin current sourced in the same domain is gradually reduced from around 40 mA to around 29 mA, $V_{OH} \geq 2.64\text{ V}$, as the number of current-source pins increases.
3. Pins occupied by flash and/or PSRAM in the VDD_SDIO power domain were excluded from the test.

5.4 Wi-Fi Radio

Table 8: Wi-Fi Radio Characteristics

Parameter	Condition	Min	Typical	Max	Unit
Input frequency	-	2412	-	2484	MHz
Output impedance*	-	-	*	-	Ω
TX power	11n, MCS7	12	13	14	dBm
	11b mode	17.5	18.5	20	dBm
Sensitivity	11b, 1 Mbps	-	-98	-	dBm
	11b, 11 Mbps	-	-89	-	dBm
	11g, 6 Mbps	-	-92	-	dBm
	11g, 54 Mbps	-	-74	-	dBm
	11n, HT20, MCS0	-	-91	-	dBm
	11n, HT20, MCS7	-	-71	-	dBm
	11n, HT40, MCS0	-	-89	-	dBm
	11n, HT40, MCS7	-	-69	-	dBm
Adjacent channel rejection	11g, 6 Mbps	-	31	-	dB
	11g, 54 Mbps	-	14	-	dB
	11n, HT20, MCS0	-	31	-	dB
	11n, HT20, MCS7	-	13	-	dB

*For the modules that use IPEX antennas, the output impedance is 50 Ω . For other modules without IPEX antennas, users do not need to concern about the output impedance.

5.5 BLE Radio

5.5.1 Receiver

Table 9: Receiver Characteristics – BLE

Parameter	Conditions	Min	Typ	Max	Unit
Sensitivity @30.8% PER	-	-	-97	-	dBm
Maximum received signal @30.8% PER	-	0	-	-	dBm
Co-channel C/I	-	-	+10	-	dB
Adjacent channel selectivity C/I	F = F0 + 1 MHz	-	-5	-	dB
	F = F0 - 1 MHz	-	-5	-	dB
	F = F0 + 2 MHz	-	-25	-	dB
	F = F0 - 2 MHz	-	-35	-	dB
	F = F0 + 3 MHz	-	-25	-	dB
	F = F0 - 3 MHz	-	-45	-	dB
Out-of-band blocking performance	30 MHz ~ 2000 MHz	-10	-	-	dBm
	2000 MHz ~ 2400 MHz	-27	-	-	dBm
	2500 MHz ~ 3000 MHz	-27	-	-	dBm
	3000 MHz ~ 12.5 GHz	-10	-	-	dBm
Intermodulation	-	-36	-	-	dBm

5.5.2 Transmitter

Table 10: Transmitter Characteristics – BLE

Parameter	Conditions	Min	Typ	Max	Unit
RF transmit power	-	-	0	-	dBm
Gain control step	-	-	3	-	dBm
RF power control range	-	-12	-	+12	dBm
Adjacent channel transmit power	F = F0 ± 2 MHz	-	-52	-	dBm
	F = F0 ± 3 MHz	-	-58	-	dBm
	F = F0 ± > 3 MHz	-	-60	-	dBm
Δf_{1avg}	-	-	-	265	kHz
Δf_{2max}	-	247	-	-	kHz
$\Delta f_{2avg}/\Delta f_{1avg}$	-	-	-0.92	-	-
ICFT	-	-	-10	-	kHz
Drift rate	-	-	0.7	-	kHz/50 μ s
Drift	-	-	2	-	kHz

5.6 Reflow Profile

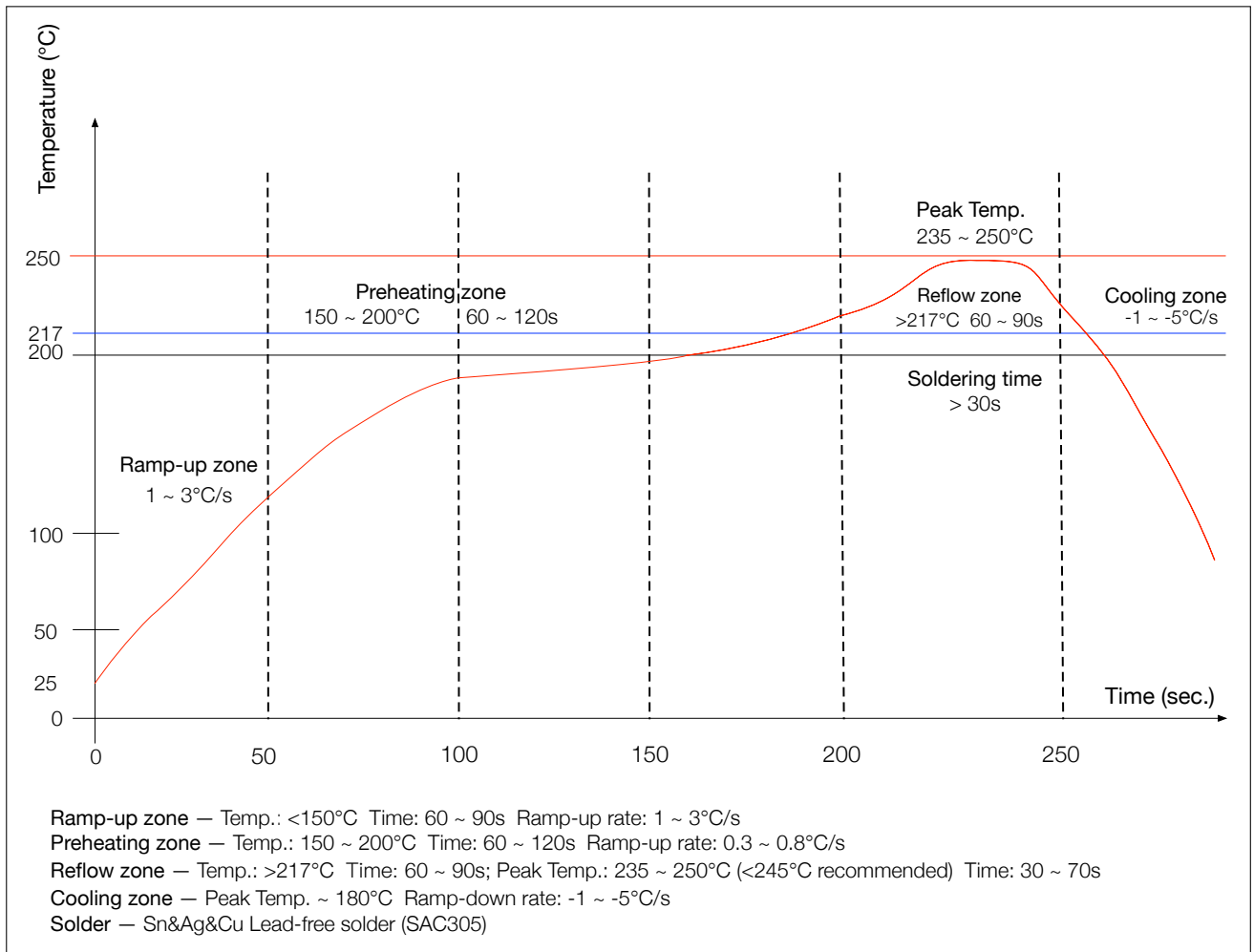

Figure 2: Reflow Profile

6. Schematics

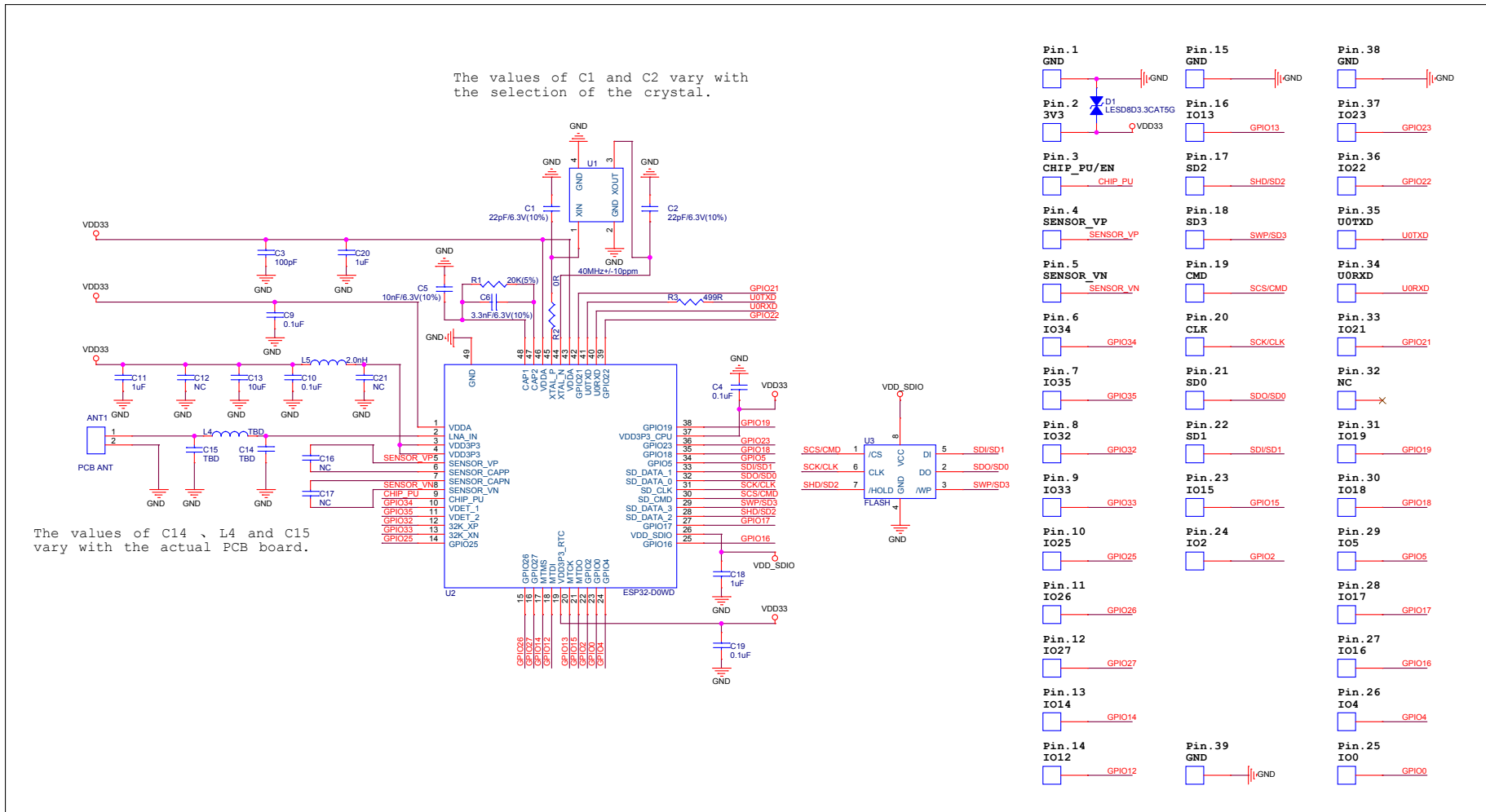

Figure 3: ESP32-WROOM-32D Schematics

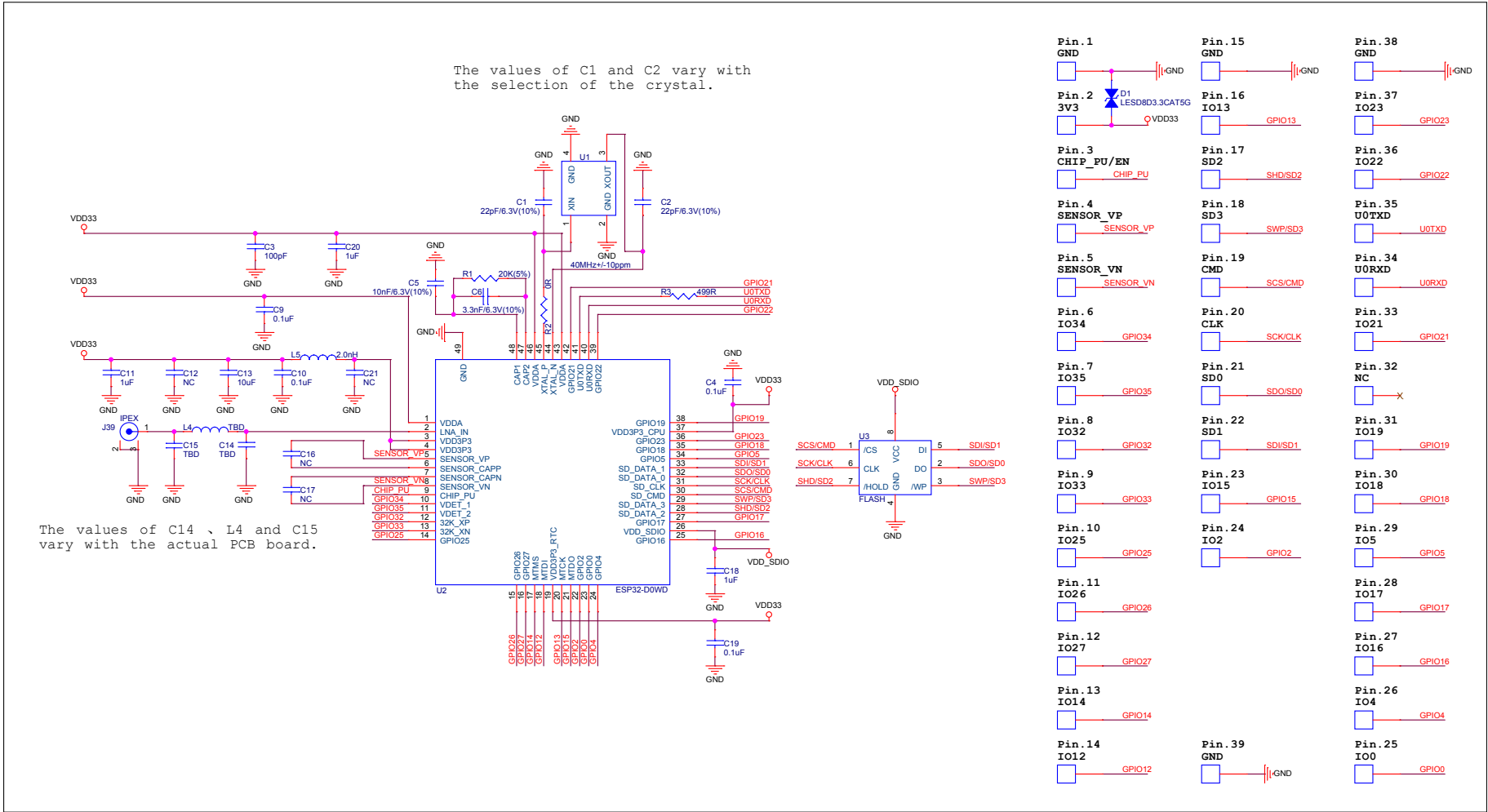

Figure 4: ESP32-WROOM-32U Schematics

7. Peripheral Schematics

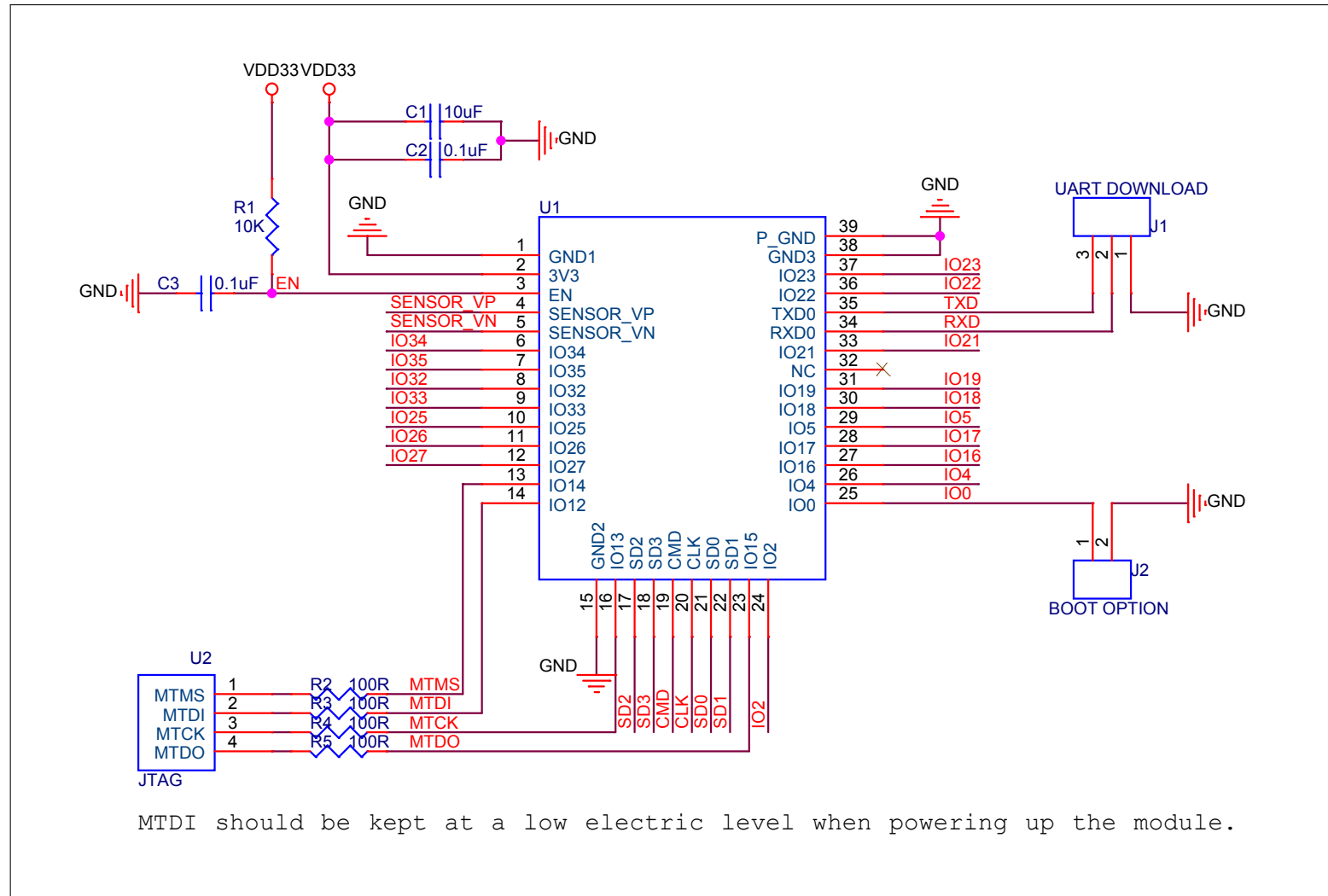

Figure 5: ESP32-WROOM-32D & ESP32-WROOM-32U Peripheral Schematics

Note:

- Soldering Pad 39 to the Ground is not necessary for a satisfactory thermal performance. If users do want to solder it, they need to ensure that the correct quantity of soldering paste is applied.
- When ESP32 is powered on and off repeatedly by switching the power rails, and there is a large capacitor on the 3V3 rail, a discharge circuit can be added to the 3V3 rail to ensure proper power-on-reset. Please find the discharge circuit in Chapter **Peripheral Schematics**, in [ESP32-WROOM-32 Datasheet](#).
- When battery is used as the power supply for ESP32 series of chips and modules, a supply voltage supervisor is recommended to avoid boot failure due to low voltage. Users are recommended to pull CHIP_PU low if the power supply for ESP32 is below 2.3 V. For the reset circuit, please refer to Chapter **Peripheral Schematics**, in [ESP32-WROOM-32 Datasheet](#).

8. Physical Dimensions

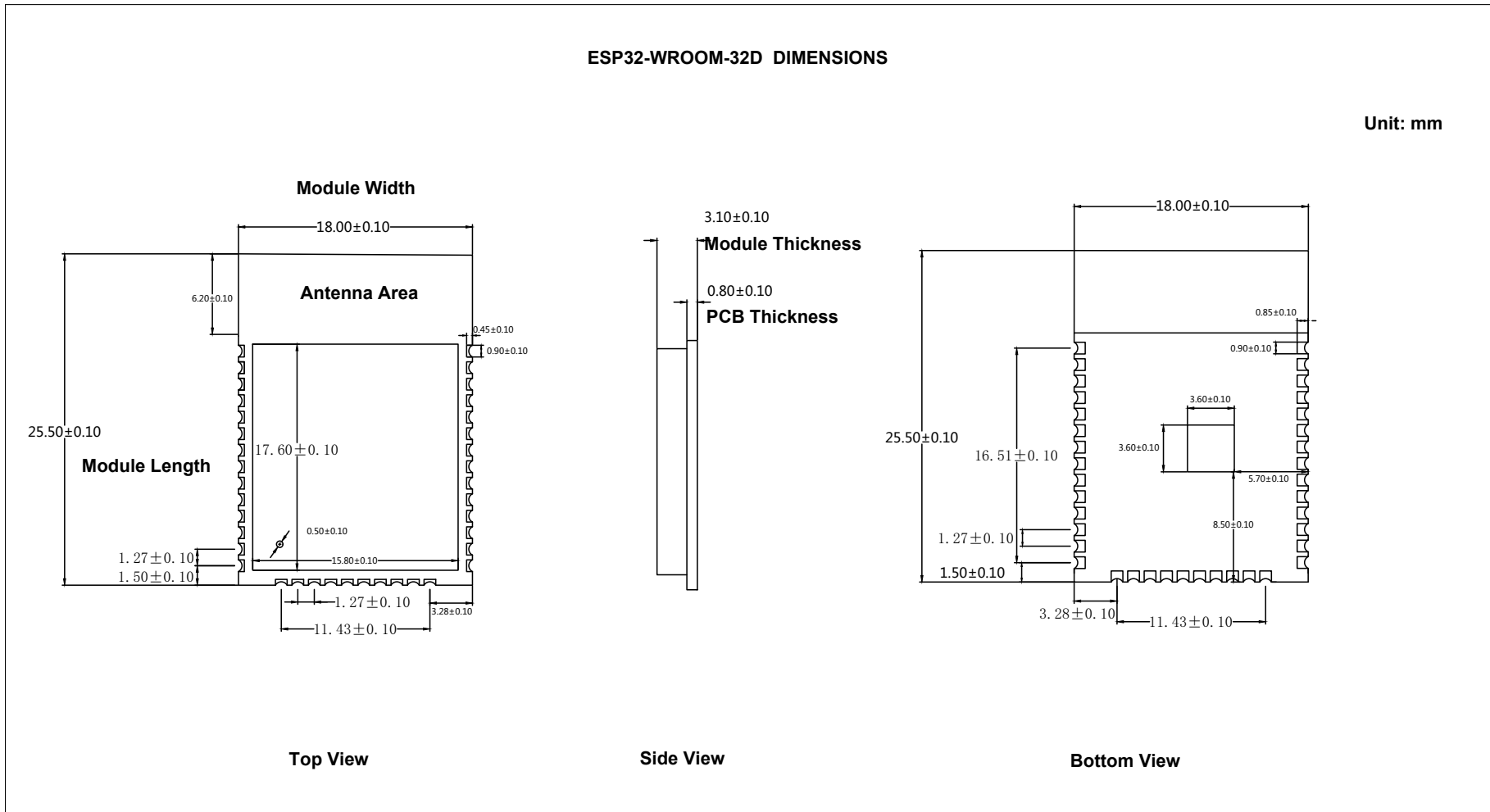

Figure 6: Physical Dimensions of ESP32-WROOM-32D

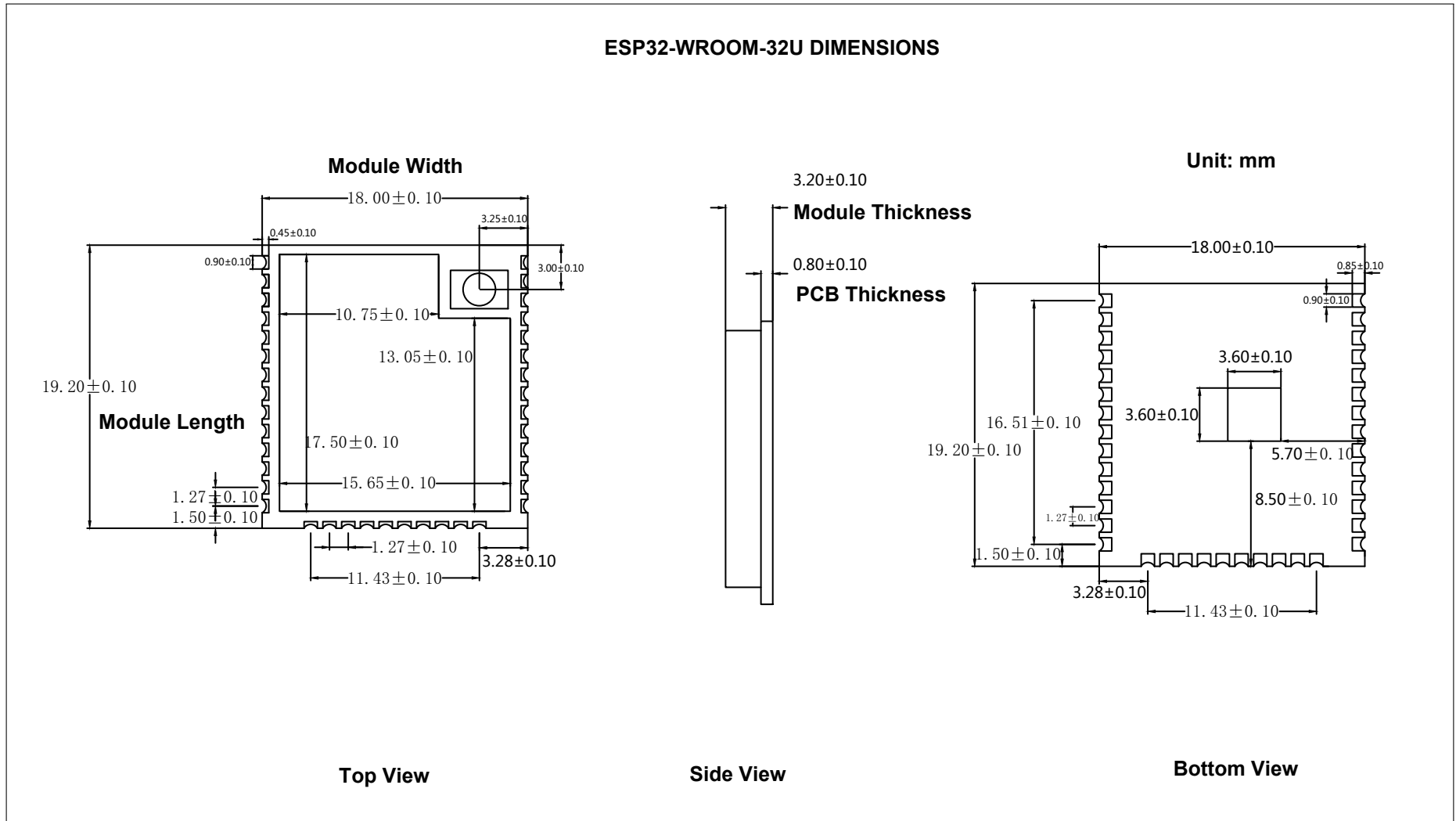

Figure 7: Physical Dimensions of ESP32-WROOM-32U

9. Recommended PCB Land Pattern

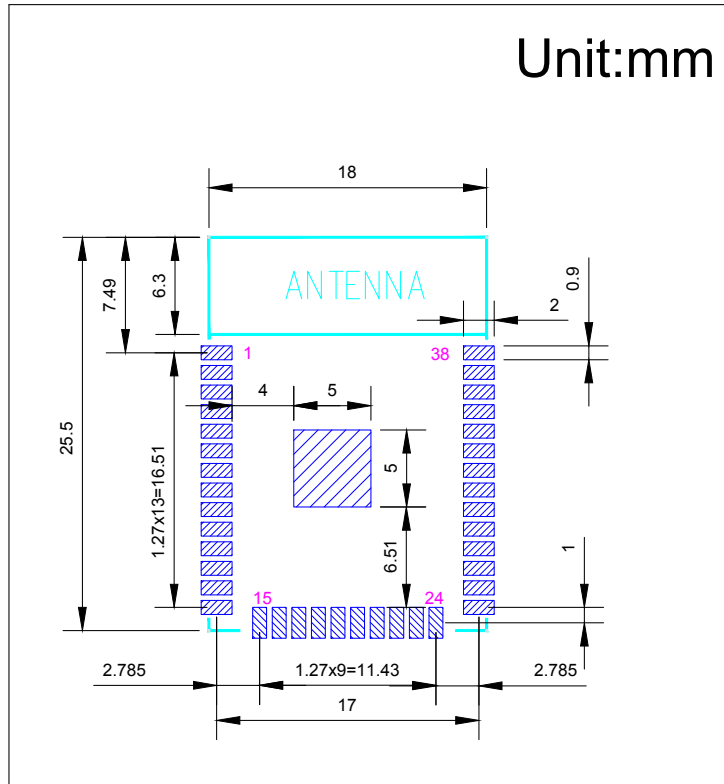

Figure 8: Recommended PCB Land Pattern of ESP32-WROOM-32D

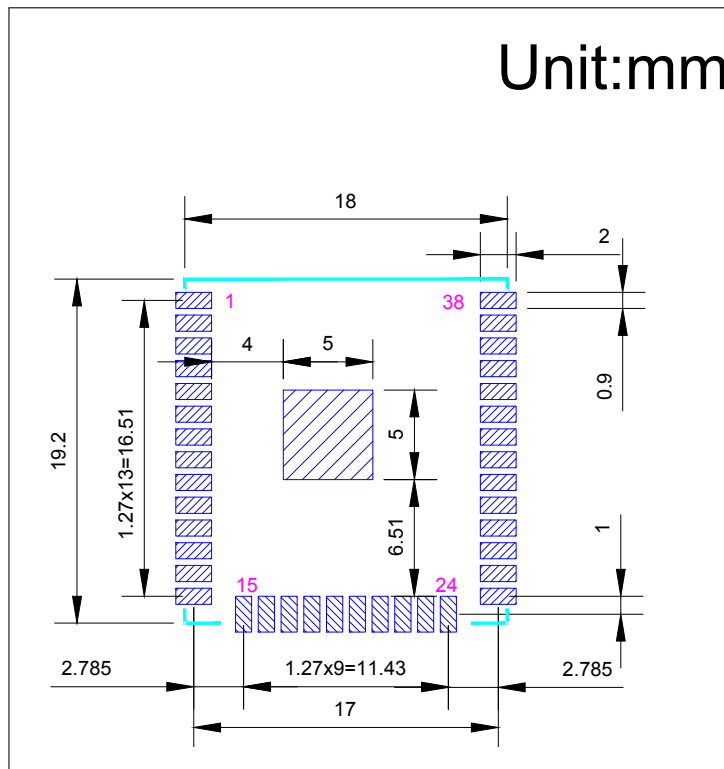

Figure 9: Recommended PCB Land Pattern of ESP32-WROOM-32U

10. U.FL Connector Dimensions

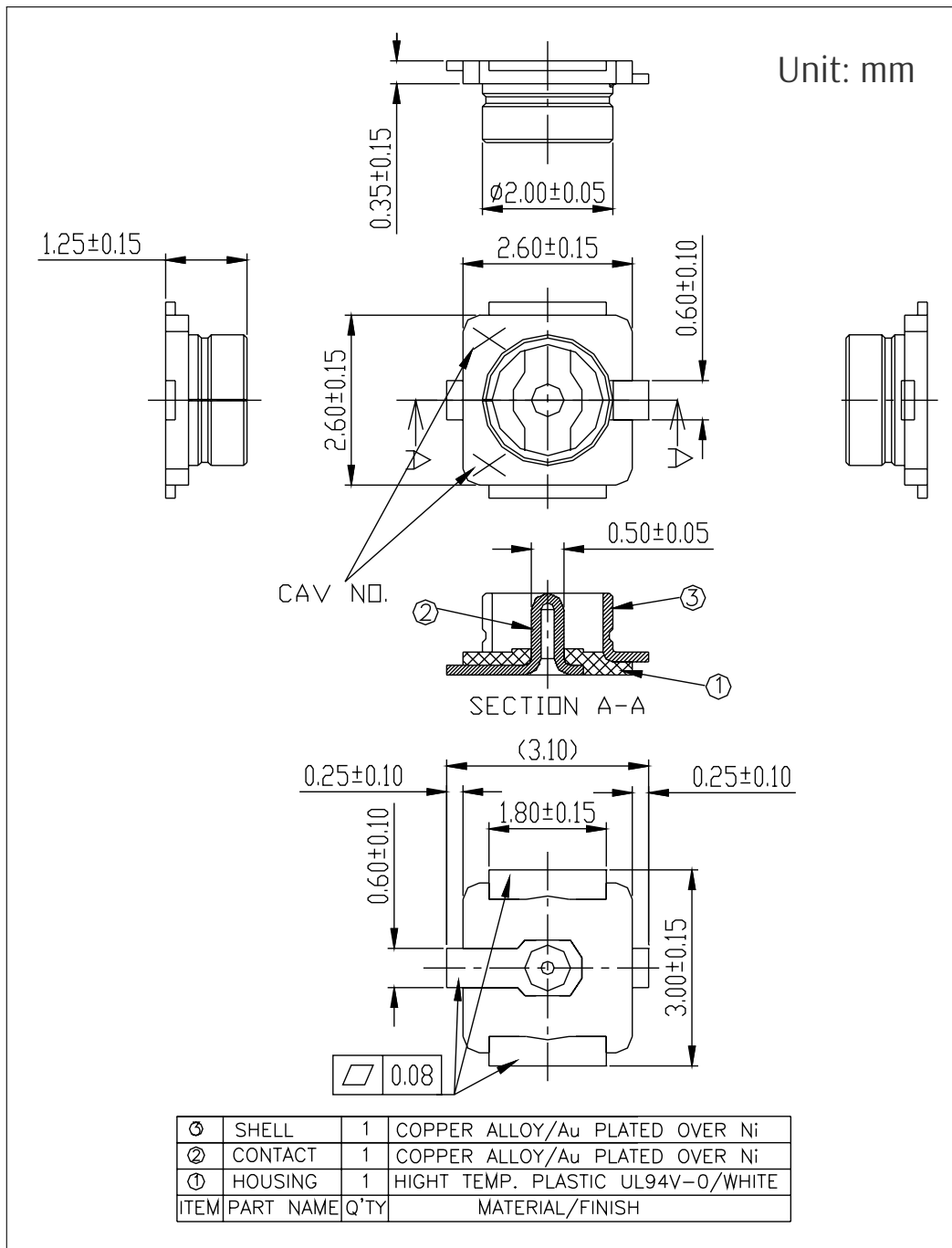

Figure 10: ESP32-WROOM-32U U.FL Dimensions

11. Learning Resources

11.1 Must-Read Documents

The following link provides documents related to ESP32.

- [ESP32 Datasheet](#)
This document provides an introduction to the specifications of the ESP32 hardware, including overview, pin definitions, functional description, peripheral interface, electrical characteristics, etc.
- [ESP-IDF Programming Guide](#)
It hosts extensive documentation for ESP-IDF ranging from hardware guides to API reference.
- [ESP32 Technical Reference Manual](#)
The manual provides detailed information on how to use the ESP32 memory and peripherals.
- [ESP32 Hardware Resources](#)
The zip files include the schematics, PCB layout, Gerber and BOM list of ESP32 modules and development boards.
- [ESP32 Hardware Design Guidelines](#)
The guidelines outline recommended design practices when developing standalone or add-on systems based on the ESP32 series of products, including the ESP32 chip, the ESP32 modules and development boards.
- [ESP32 AT Instruction Set and Examples](#)
This document introduces the ESP32 AT commands, explains how to use them, and provides examples of several common AT commands.
- [Espressif Products Ordering Information](#)

11.2 Must-Have Resources

Here are the ESP32-related must-have resources.

- [ESP32 BBS](#)
This is an Engineer-to-Engineer (E2E) Community for ESP32 where you can post questions, share knowledge, explore ideas, and help solve problems with fellow engineers.
- [ESP32 GitHub](#)
ESP32 development projects are freely distributed under Espressif's MIT license on GitHub. It is established to help developers get started with ESP32 and foster innovation and the growth of general knowledge about the hardware and software surrounding ESP32 devices.
- [ESP32 Tools](#)
This is a webpage where users can download ESP32 Flash Download Tools and the zip file "ESP32 Certification and Test".
- [ESP-IDF](#)
This webpage links users to the official IoT development framework for ESP32.
- [ESP32 Resources](#)
This webpage provides the links to all available ESP32 documents, SDK and tools.

Revision History

Date	Version	Release notes
2018.10	V1.7	Added notice on module custom options under Table 2; Added "Cumulative IO output current" entry to Table 5: Absolute Maximum Ratings; Added more parameters to Table 7: DC Characteristics.
2018.09	V1.6	Updated the hole diameter in the shield from 1.00 mm to 0.50 mm, in Figure 6.
2018.08	V1.5	<ul style="list-style-type: none"> Added certifications and reliability test items the module has passed in Table 2: ESP32-WROOM-32D and ESP32-WROOM-32U Specifications, and removed software-specific information; Updated section 3.4: RTC and Low-Power Management; Changed the modules' dimensions; Updated Figure 8 and 7: Physical Dimensions; Updated Table 8: Wi-Fi Radio.
2018.06	V1.4	<ul style="list-style-type: none"> Deleted Temperature Sensor in Table 2: ESP32-WROOM-32D & ESP32-WROOM-32U Specifications; Updated Chapter 3: Functional Description; Added notes to Chapter 7: Peripheral Schematics; Added Chapter 9: Recommended PCB Land Pattern; Changes to electrical characteristics: <ul style="list-style-type: none"> Updated Table 5: Absolute Maximum Ratings; Added Table 6: Recommended Operating Conditions; Added Table 7: DC Characteristics; Updated the values of "Gain control step", "Adjacent channel transmit power" in Table 10: Transmitter Characteristics - BLE.
2018.04	V1.3	Updated Figure 4 ESP32-WROOM-32U Schematics and Figure 3 ESP32-WROOM-32D Schematics.
2018.02	V1.2	Update Figure 4 ESP32-WROOM-32U Schematics.
2018.02	V1.1	Updated Chapter 6 Schematics. Deleted description of low-noise amplifier. Replaced the module name ESP-WROOM-32D with ESP32-WROOM-32D. Added information about module certification in Table 2. Updated the description of eFuse bits in Section 3.1.
2017.11	V1.0	First release.

Mouser Electronics

Authorized Distributor

Click to View Pricing, Inventory, Delivery & Lifecycle Information:

Espressif:

[ESP32-WROOM-32U \(16MB\)](#) [ESP32-WROOM-32U \(8MB\)](#) [ESP32-WROOM-32D \(8MB\)](#) [ESP32-WROOM-32D \(16MB\)](#) [ESP32-WROOM-32D](#) [ESP32-WROOM-32U](#)